



2/2-way proportional valve

- Excellent dynamics and turn-down ratio
- 0 ... 10 bar ¹⁾
- DN 0.05 ... 1.0 mm
- 1/8" or sub-base version

Type 2822 can be combined with...



Type 8605

Digital control electronics
DIN-rail version



Type 2507

Cable plug



Typ 8611

Universal Controller

The direct-acting proportional valve Type 2822 can be used as a control valve for process control and is suitable for technical vacuum. A special design minimizes frictional and stick-slip effects and provides an excellent span, repeatability and sensitivity.

The valve is driven either by DC or by a high-frequency PWM signal. With the input signal at zero, it closes tightly owing to an elastomer seat seal. Because of its almost silent operation, the valve is specially suitable for medical applications.

Valve operation A

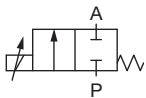

direct acting 2-way proportional valve
normally closed

Valve control takes place through the control electronics of Type 8605, which converts an analogue input signal into a PWM signal²⁾.

Further, functional features of the Type 8605 electronic control unit:

- Temperature compensation for coil heating by internal current regulation
- Simple zero and span settings
- Ramp function to dampen fast status changes

¹⁾ Pressure data [bar]: Overpressure with respect to atmospheric pressure

²⁾ PWM pulse-width modulation

³⁾ Characteristic data of control behaviour depends on process conditions

Technical data - valve	
Body material	Brass, Stainless steel
Seal material	FKM, others on request
Media	Neutral gases, liquids
Medium temperature	-10 ... +90 °C
Ambient temperature	max. +55 °C
Viscosity	max. 21 mm ² /s
Operating voltage	24 V DC
Power consumption	1 W (to DN 0.4) 2 W (DN 0.6 ... DN 1.0)
Duty cycle	100 % continuously rated
Port connection	Sub-base, G 1/8, NPT 1/8, others on request
Electric connection	Flying leads, 30 cm or cable plug Type 2507 Form B, Industrial standard on request
Installation	As required, preferably with actuator in upright position
Response time (10-90%)	< 10ms
Typical control data ³⁾	
Hysteresis	< 10 %
Repeatability	< 0.25 % F.S.
Sensitivity	< 0.1 % F.S.
Width of backlash	< 0.1 % F.S.
Turn-down ratio	1:500
Protection class - valve	IP65

Technical data - control electronics Type 8605 (see separate datasheet)

Characteristics of a proportional valve

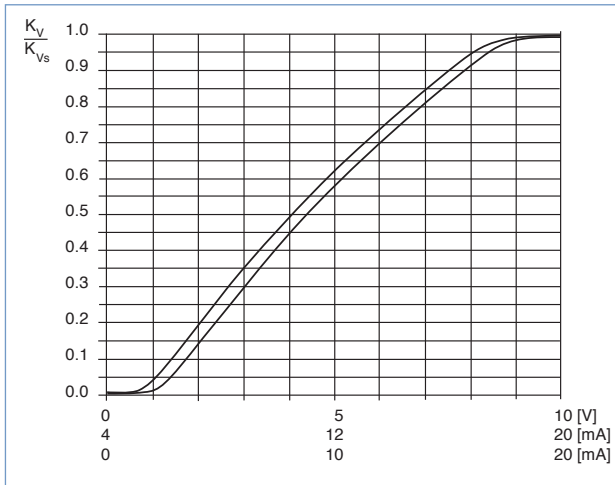

Advice for valve sizing

In continuous flow applications, the choice of appropriate valve size is much more important than with on/off valves. The optimum size should be selected such that the resulting flow in the system is not unnecessarily reduced by the valve. However, a sufficient part of the pressure drop should be taken across the valve even when it is fully opened.

recommended value: $\Delta p_{\text{valve}} > 30\%$ of total pressure drop within the system

For that reason take advantage of Bürkert competent engineering services during the planning phase!

Determination of the kv value

Pressure drop	kv value for liquids [m³/h]	kv value for gases [m³/h]
Subcritical $p_2 > \frac{p_1}{2}$	$= Q \sqrt{\frac{\rho}{1000 \Delta p}}$	$= \frac{Q_N}{514} \sqrt{\frac{T_1 \rho_N}{p_2 \Delta p}}$
Supercritical $p_2 < \frac{p_1}{2}$	$= Q \sqrt{\frac{\rho}{1000 \Delta p}}$	$= \frac{Q_N}{257 p_1} \sqrt{T_1 \rho_N}$

- k_v Flow coefficient [m³/h] ¹⁾
- Q_N Standard flow rate [m³/h] ²⁾
- p_1 Inlet pressure [bar] ³⁾
- p_2 Outlet pressure [bar] ³⁾
- Δp Differential pressure $p_1 - p_2$ [bar]
- ρ Density [kg/m³]
- ρ_N Standard density [kg/m³]
- T_1 Temperature if fluid medium [(273+t)K]

¹⁾ measured for water, $\Delta p = 1$ bar, via the device

²⁾ Standard conditions at 1.013 bar³⁾ and 0 °C (273K)

³⁾ Absolute pressure

Ordering chart

All devices with FKM seal and flying electrical leads with 30 cm cable.

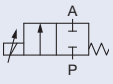
Circuit function	Orifice [mm]	Port connection	kvs value water [m ³ /h] ¹⁾	QNn value [l/min] ²⁾	Maximum pressure [bar] ³⁾	Power consumption [W]	Maximum coil current [mA]	Item no. Brass body	Item no. Stainless steel body
	0.05	sub-base FK01	0.00006	0.06	10	1	65	184 760	184 761
		G 1/8	0.00006	0.06	10	1	65	on request	on request
		NPT 1/8	0.00006	0.06	10	1	65	on request	on request
	0.1	sub-base FK01	0.00025	0.27	10	1	65	184 749	184 759
		G 1/8	0.00025	0.27	10	1	65	on request	on request
		NPT 1/8	0.00025	0.27	10	1	65	on request	on request
	0.2	sub-base FK01	0.001	1	10	1	65	159 260	184 748
		G 1/8	0.001	1	10	1	65	on request	on request
		NPT 1/8	0.001	1	10	1	65	on request	on request
	0.3	sub-base FK01	0.002	2	10	1	65	156 308	156 310
		G 1/8	0.002	2	10	1	65	156 309	156 311
		NPT 1/8	0.002	2	10	1	65	164 581	164 622
	0.4	sub-base FK01	0.004	4	8	1	65	156 295	152 693
		G 1/8	0.004	4	8	1	65	156 296	156 297
		NPT 1/8	0.004	4	8	1	65	164 582	164 623
	0.6	sub-base FK01	0.010	11	6	2	90	156 298	160 571
		G 1/8	0.010	11	6	2	90	159 691	160 595
		NPT 1/8	0.010	11	6	2	90	164 606	164 624
	0.8	sub-base FK01	0.018	19	3	2	90	156 301	160 596
		G 1/8	0.018	19	3	2	90	156 302	156 303
		NPT 1/8	0.018	19	3	2	90	164 583	164 625
	1.0	sub-base FK01	0.027	29	2	2	90	156 304	156 306
		G 1/8	0.027	29	2	2	90	156 305	156 307
		NPT 1/8	0.027	29	2	2	90	164 584	164 626

¹⁾ kVs value: Flow rate value for water, measured at +20 °C and 1 bar pressure differential over a fully opened valve.²⁾ QNn value: Flow rate value for air with inlet pressure of 6 bar₁), 1 bar pressure differential and +20 °C.³⁾ Pressure data [bar]: Overpressure with respect to atmospheric pressure

▪ **Please note** that the valves are delivered without control electronics (please see the datasheet for Type 8605)

Further versions on request



Materials

Seal material FFKM - Resistant to aggressive media
Seal material EPDM



Analytical

Oxygen version
Part oil-, fat- and silicon free



Electrical Connection

12 V Coil
Cable plug Type 2507 Form B, Industrial standard



Approvals

UR
CSA

Dimensions [mm]

Flying leads connection

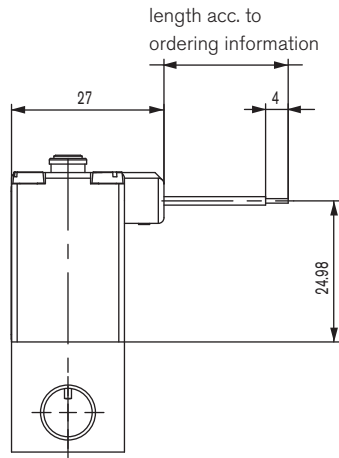

Threaded body
(G 1/8, NPT 1/8)

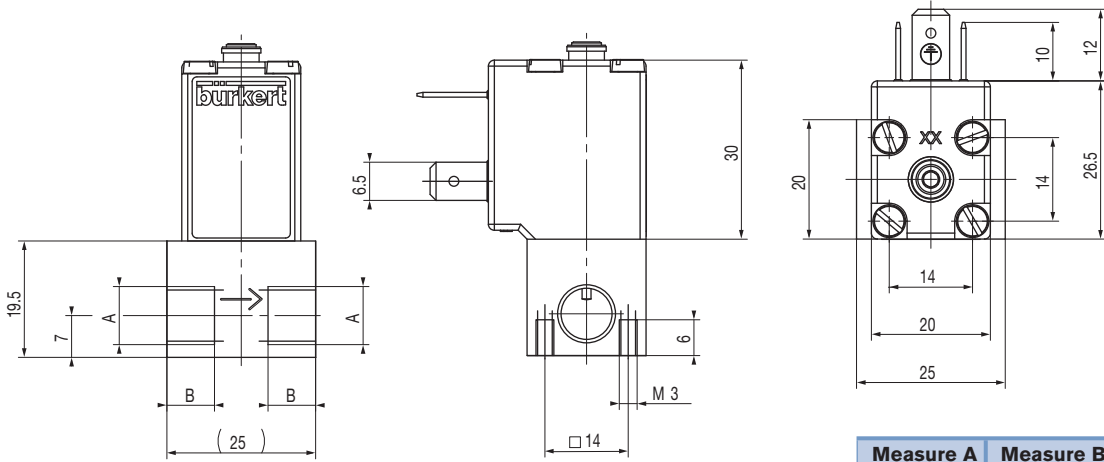

Sub-base body

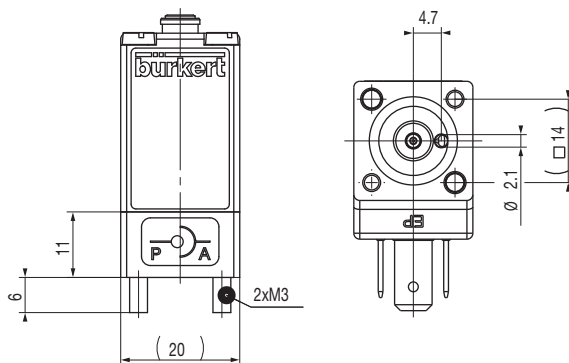

For product inquiries, use the specification sheet for proportional valves!

Note
You can fill out the fields directly in the PDF file before printing out the form.

Design data for proportional valves

▶ Please fill out this form and send to your local Bürkert Sales Centre* with your inquiry or order

Company	Contact person
Customer no.	Dept.
Address	Tel./Fax
Town / Postcode	E-Mail

<input type="checkbox"/> = Mandatory fields	<input type="text"/> Quantity	<input type="text"/> Desired delivery date
Process data		
<input type="checkbox"/> Medium	<input type="text"/>	
<input type="checkbox"/> State of medium	<input type="checkbox"/> liquid	<input type="checkbox"/> gaseous <input type="checkbox"/> vaporous
<input type="checkbox"/> Medium temperature	<input type="text"/> °C	
<input type="checkbox"/> Maximum flow rate	$Q_{nom} =$ <input type="text"/>	Unit: <input type="text"/>
<input type="checkbox"/> Minimum flow rate	$Q_{min} =$ <input type="text"/>	Unit: <input type="text"/>
<input type="checkbox"/> Inlet pressure at nominal operation	$p_1 =$ <input type="text"/>	barg
<input type="checkbox"/> Outlet pressure at nominal operation	$p_2 =$ <input type="text"/>	barg
<input type="checkbox"/> Maximum inlet pressure	$p_{1max} =$ <input type="text"/>	barg
<input type="checkbox"/> Ambient temperature	<input type="text"/> °C	
Additional specifications		
<input type="checkbox"/> Body material	<input type="checkbox"/> Brass	<input type="checkbox"/> Stainless steel
<input type="checkbox"/> Seal material	<input type="checkbox"/> FKM	<input type="checkbox"/> other <input type="text"/>

Note Please state all pressure values as **overpressures with** respect to atmospheric [barg].

DTS 1000017534 EN Version: K Status: RL (released | freigegeben | valide) printed: 31.03.2009

To find your nearest Bürkert facility, click on the orange box →

www.burkert.com

In case of special application conditions, please consult for advice.

Subject to alterations
© Christian Bürkert GmbH & Co. KG

0904/7_EU-en_00891870